



# Lethbridge Park Public School - Preschool Blue Class

## Learning from Home Educational Program/Schedule

### Week 6 Term 3 2021 Wednesday 18.08.2021 to Friday 20.08.2021

**Wednesday Home Skills:** Help with the laundry – hanging out the clothes, folding and putting away your belongings  
**Thursday Home Skills:** Help sort the recycling at your house. Are there any items that you could use for our creative experience this week?  
**Friday Home Skills:** Help look after your family pet. Help tidy up the garden – weeding putting rubbish in the bin

**Wednesday exploring space** – reading a non-fiction text about space and creating our own rocket image using 2D shapes @ 10 am  
**Thursday preschool singing Zoom Session @ 10am** (bring along your song packs/puppets to help us sing some of our favourite songs)  
**Friday preschool story time and creative art zoom session @ 10am** creating your own solar system

**Wednesday:** pencil control and cutting practice  
**Thursday:** Have an adult write your name using a highlighter, trace over the letters of your name then try and write it all by yourself % little spacemen numeracy colouring sheets.  
**Friday:** Cut and colour to create your own solar system  
**Art for Kids Hub:** <https://www.youtube.com/user/ArtforKidsHub> to support children in their drawing

**Break Time - Have a piece of fresh fruit or vegetable. Try a new fruit or vegetable today.**

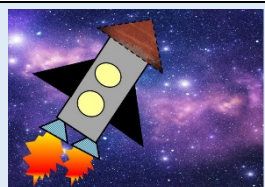

#### Wednesday 18.08.2021

Join Ms Jacqui on Wednesday's Zoom session to explore and find out about space. Then use the 2D shapes –

rectangle, circle and triangles. If completing this experience as a participant in the Zoom session, please come with your shapes already cut out, you can also add to your rocket from items that you could find in and around your home.

Supportive exploration of space **video links:**  
<https://youtu.be/BU9IOXjJogQ>

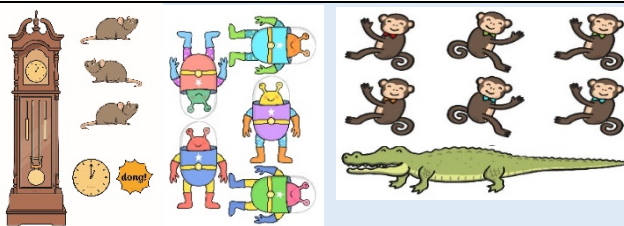

**This week's languages experiences:** promote the exploration mathematical concepts of number.

Make your own stick – puppets to sing along with our favourite songs and nursery rhymes.

#### Video links to songs:

5 Little Spacemen [https://youtu.be/2E3p\\_51tJx0](https://youtu.be/2E3p_51tJx0)  
Hickory Dickory Dock <https://youtu.be/FHFO04s3DTk>  
5 Cheeky Monkeys Swinging in a tree <https://youtu.be/WQ14sWuvaUM>



**Friday:** cut and colour the planets and space inspired characters (or draw your own) to create your own solar system, make it colourful

#### Video links:

The Planet Song <https://youtu.be/mQrlgH97v94>  
The Solar System <https://youtu.be/-Eq1FLi5RHA>

## Side-sliding



Take a side step.



Slide together. Slide together.



Slide on a line (creaky slide) with the right foot in front.

### Old Grey Cat

Assemble a team to create a cat with the same number of legs as the team they are the old grey cat. Choose both sides and decide on an order of legs to be removed to create a cat that may have two legs, one leg and one tail, or a head, but not a tail. The only rule is that you can't have a head without a tail. The cat can have any number of legs. There is no limit on the number of legs you can have.

### Snail Relay

Scrape out a path into a line. Mark out a path with a string. Children will be crawling on their hands and knees. They will be crawling on their hands and knees. They will be crawling on their hands and knees. They will be crawling on their hands and knees.

### Shape Game

Put out several shapes from laminated paper. Have a row of different colors for each shape. When there is a color that is not on the ground, when the child says the name of the shape, the child says the name of the shape. When the child says the name of the shape, the child says the name of the shape. When the child says the name of the shape, the child says the name of the shape.

### Line Sliding

Mark out a path with a string. Children will be crawling on their hands and knees. They will be crawling on their hands and knees. They will be crawling on their hands and knees. They will be crawling on their hands and knees.

Fundamental Movement Skills In Action      FMS for 3 – 5 year olds

## SIDE SLIDING

for preschoolers 3-5 years with Franky the Frog

**DESCRIPTION**

Side sliding is a fun way to practice your side-sliding skills. It is a fun way to practice your side-sliding skills. It is a fun way to practice your side-sliding skills. It is a fun way to practice your side-sliding skills.

**POINTS TO REMEMBER**

- 1. Keep your feet together and your arms out to the sides.
- 2. Keep your feet together and your arms out to the sides.
- 3. Keep your feet together and your arms out to the sides.
- 4. Keep your feet together and your arms out to the sides.
- 5. Keep your feet together and your arms out to the sides.

**TEACHING IDEAS**

1. Use a frog to lead the way.
2. Use a frog to lead the way.
3. Use a frog to lead the way.
4. Use a frog to lead the way.

## SIDE SLIDING

for preschoolers 3-5 years with Franky the Frog

**MAKE-UP ACTIVITY**

Use your imagination to create a frog. Use your imagination to create a frog. Use your imagination to create a frog. Use your imagination to create a frog.

**WHO CAN SIDE SLIDE LIKE FRANKY THE FROG?**

Who can side slide like Franky the frog? Who can side slide like Franky the frog? Who can side slide like Franky the frog? Who can side slide like Franky the frog?

**TEACHING IDEAS**

1. Use a frog to lead the way.
2. Use a frog to lead the way.
3. Use a frog to lead the way.
4. Use a frog to lead the way.

## SIDE SLIDING

for preschoolers 3-5 years with Franky the Frog

**PARACHUTES**

Use your imagination to create a frog. Use your imagination to create a frog. Use your imagination to create a frog. Use your imagination to create a frog.

**TEACHING IDEAS**

1. Use a frog to lead the way.
2. Use a frog to lead the way.
3. Use a frog to lead the way.
4. Use a frog to lead the way.

## SIDE SLIDING

for preschoolers 3-5 years with Franky the Frog

**SIDE SLIDING SONGS**

Side sliding songs are a fun way to practice your side-sliding skills. Side sliding songs are a fun way to practice your side-sliding skills. Side sliding songs are a fun way to practice your side-sliding skills. Side sliding songs are a fun way to practice your side-sliding skills.

**COOL DOWN ACTIVITY**

Use your imagination to create a frog. Use your imagination to create a frog. Use your imagination to create a frog. Use your imagination to create a frog.

### Play Outside....

This week's FMS focus: Side Sliding <https://youtu.be/ZhDBTQuNxzw>

**Introducing investigations and experiments - STEM:** Can you make a helicopter just using paper? Test it outside to see if it flies. Make sure to ask an adult member of your family to take photos and post to Storypark about your investigation experience. **Video Support Links:** <https://youtu.be/5Vvk-gXwHDSM>

## Lunch time. Help make lunch, sit and eat together.

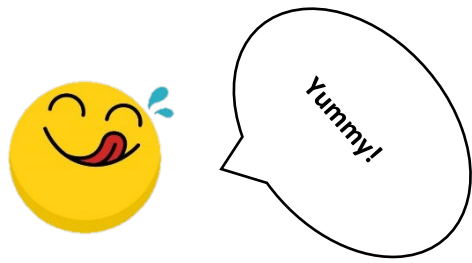



## Our PRECHOOL COMMUNITY COOKING CHALLENGE

Have you shared your family's favourite healthy snack/meal recipe yet with Ms Jacqui to go into our PRESCHOOL Community Cookbook?

**Have you shared your recipe yet?**



### Pack Away

#### Relaxation Time (Suggestions):

**Exploring this week's focused interest of Space** - <https://youtu.be/toyJv1-Cqlo> Storytime from Space – Mousestronaut

**YouTube:** Cosmic Kids Yoga.

**Listen to a story from** <https://storyboxlibrary.com.au/>

**Username:** LPPS

**Password:** Read

**Playlist:** Preschool Learning from Home Booklist

### Additional Information and Resources

**You Tube:** **Go Noodle** for interactive dancing.

Go on a virtual tour.

**Australian Museum:** <https://artsandculture.google.com/partner/australian-museum-sydney>

**Great Barrier Reef:** <https://attenboroughsreef.com/>

**Lone Pine Koala Sanctuary:** <https://youtu.be/V6rU02TLGe8>

**Sea Life aquarium:** <https://www.visitsealife.com/sydney/whats-inside/virtual-aquarium/>

**Taronga Zoo:** <https://taronga.org.au/taronga-tv>

**Science Experiments:** <https://coolscienceexperimentshq.com/>

**Little Penguins:** <https://www.penguins.org.au/virtual/>

**Mars:** <https://accessmars.withgoogle.com/>

**Virtual farm tour:** <https://www.tocal.nsw.edu.au/farm-and-facilities/tocal-farms/virtual-farm>



## Scheduled Zoom Session Links

**Wednesday** exploring space – reading a non-fiction text about space and creating our own rocket image using 2D shapes @ 10 am

**Topic:** Term 3 Week 5 - P-Blue Wednesday 18.08.2021 Exploring Space and making our own rockets using 2D shapes

**Time:** Aug 18, 2021 10:00 AM Canberra, Melbourne, Sydney

**Join Zoom Meeting** <https://nsweducation.zoom.us/j/69610231862?pwd=TTJSS1FsTWk4K3NSTEMrM3hQWTVJdz09>

**Meeting ID:** 696 1023 1862 **Passcode:** 530466

**Thursday** preschool singing Zoom Session @ 10am (bring along your song packs/puppets to help us sing some of our favourite songs)

**Topic:** Thursday Term 3, Week 6 P-Blue Singing Zoom Session

**Time:** Aug 19, 2021 10:00 AM Canberra, Melbourne, Sydney

**Join Zoom Meeting** <https://nsweducation.zoom.us/j/62973606098?pwd=ZlRyQmd3R3NBTElsRFhEN1dEQWlsQT09>

**Meeting ID:** 629 7360 6098 **Passcode:** 153315

**Friday** preschool story time and creative art zoom session @ 10am **creating your own solar system**

**Topic:** Term 3, Week 5 P-Blue Friday 20.08.2021 Making our own solar systems

**Time:** Aug 20, 2021 05:00 AM Canberra, Melbourne, Sydney

**Join Zoom Meeting** <https://nsweducation.zoom.us/j/62883751059?pwd=R2FScVJlVktBbGxOQ1BsRDFocjBXdz09>

**Meeting ID:** 628 8375 1059 **Passcode:** 036922

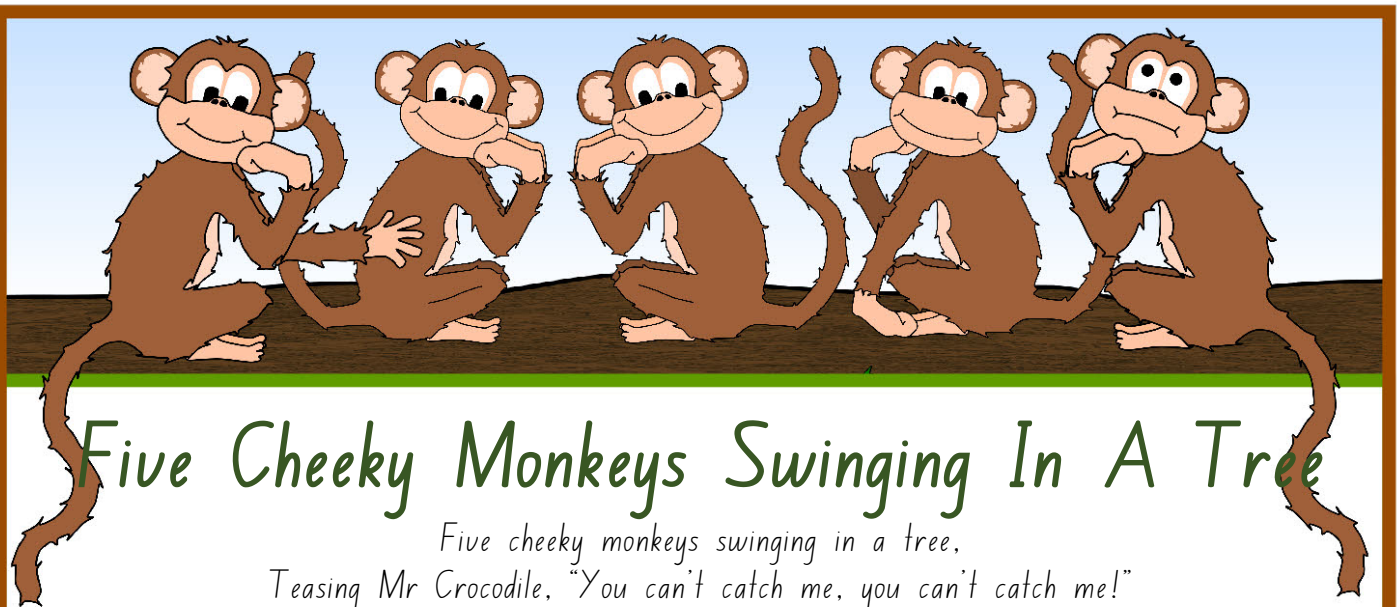

## Five Cheeky Monkeys Swinging In A Tree

Five cheeky monkeys swinging in a tree,  
Teasing Mr Crocodile, "You can't catch me, you can't catch me!"  
Along comes Mr Crocodile swimming through the swamp,  
Along comes Mr Crocodile, **CHOMP, CHOMP, CHOMP!**

Four cheeky monkeys swinging in a tree,  
Teasing Mr Crocodile, "You can't catch me, you can't catch me!"  
Along comes Mr Crocodile swimming through the swamp,  
Along comes Mr Crocodile, **CHOMP, CHOMP, CHOMP!**

Three cheeky monkeys swinging in a tree,  
Teasing Mr Crocodile, "You can't catch me, you can't catch me!"  
Along comes Mr Crocodile swimming through the swamp,  
Along comes Mr Crocodile, **CHOMP, CHOMP, CHOMP!**

Two cheeky monkeys swinging in a tree,  
Teasing Mr Crocodile, "You can't catch me, you can't catch me!"  
Along comes Mr Crocodile swimming through the swamp,  
Along comes Mr Crocodile, **CHOMP, CHOMP, CHOMP!**

One cheeky monkey swinging in a tree,  
Teasing Mr Crocodile, "You can't catch me, you can't catch me!"  
Along comes Mr Crocodile swimming through the swamp,  
Along comes Mr Crocodile, **CHOMP, CHOMP, CHOMP!**

Away swims Mr Crocodile, as full as can be.

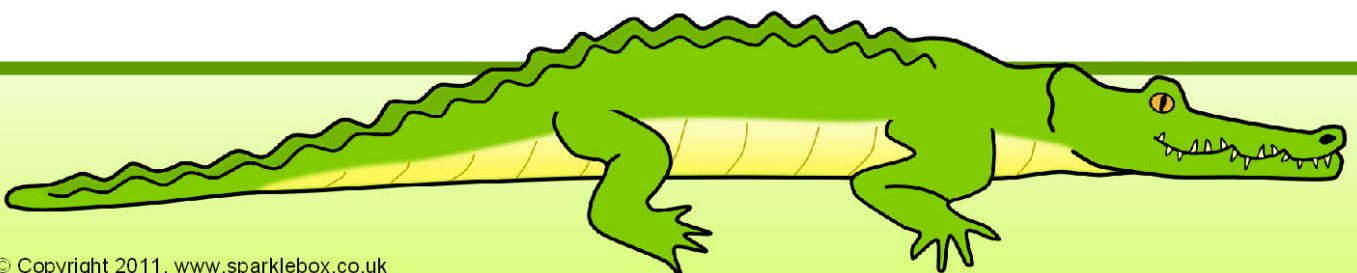

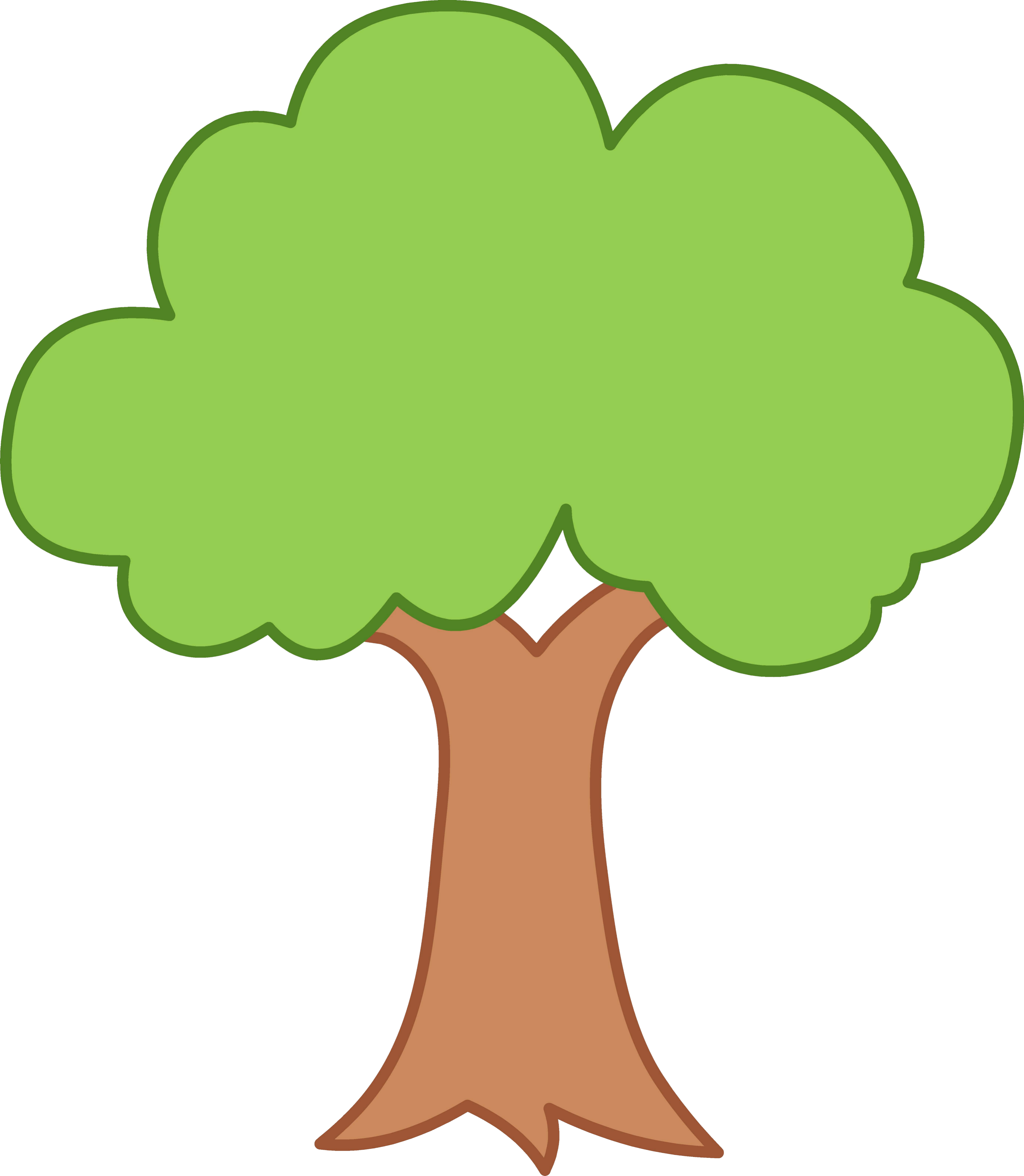



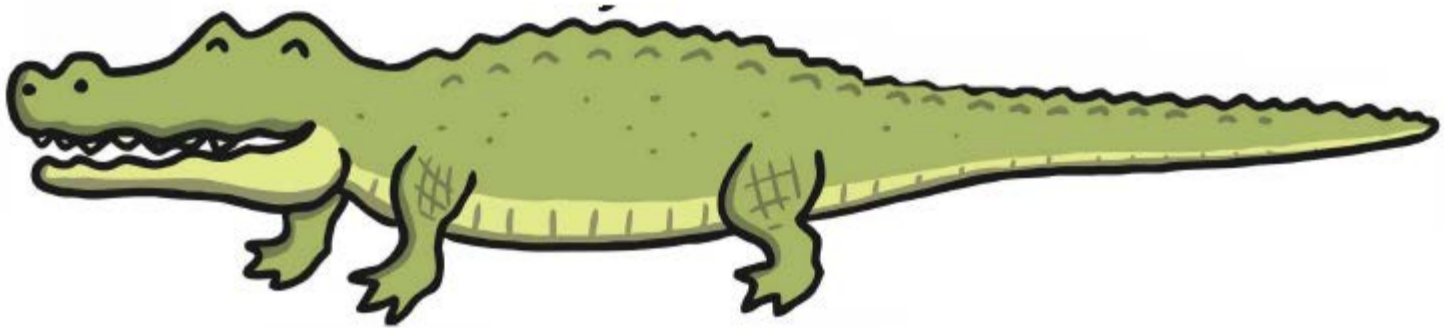



# Hickory Dickory Dock

Hickory Dickory Dock,  
The mouse ran up the clock.

The clock struck one,  
The mouse ran down,  
Hickory Dickory Dock.



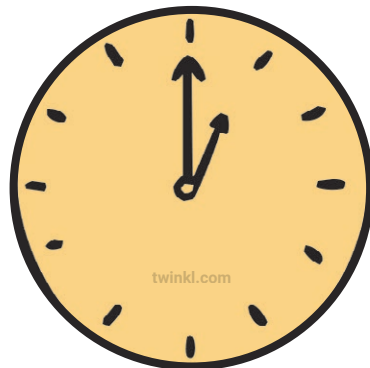
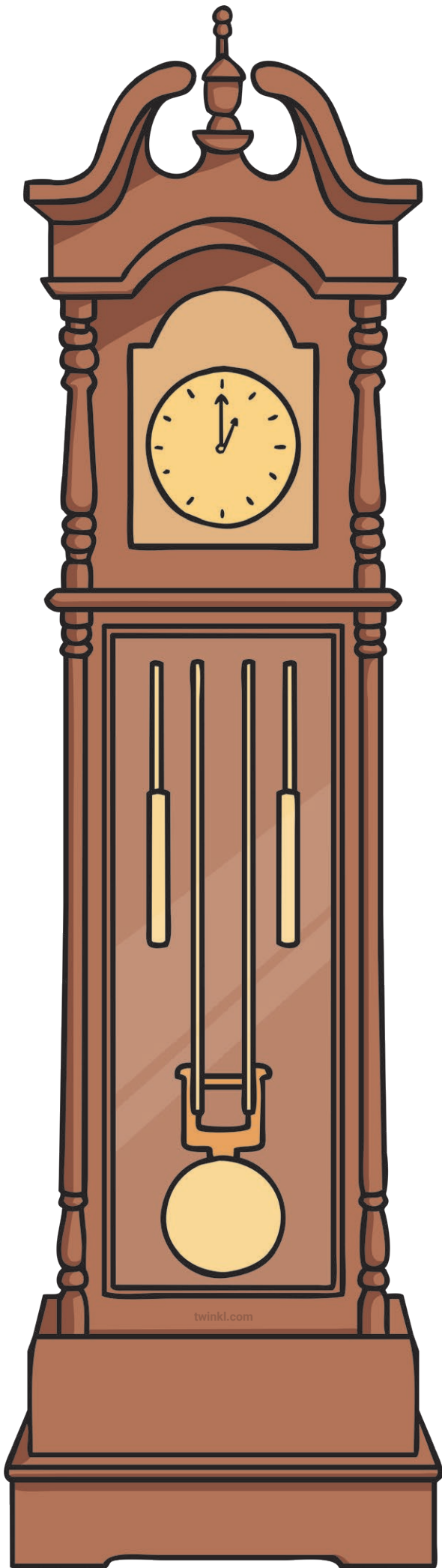





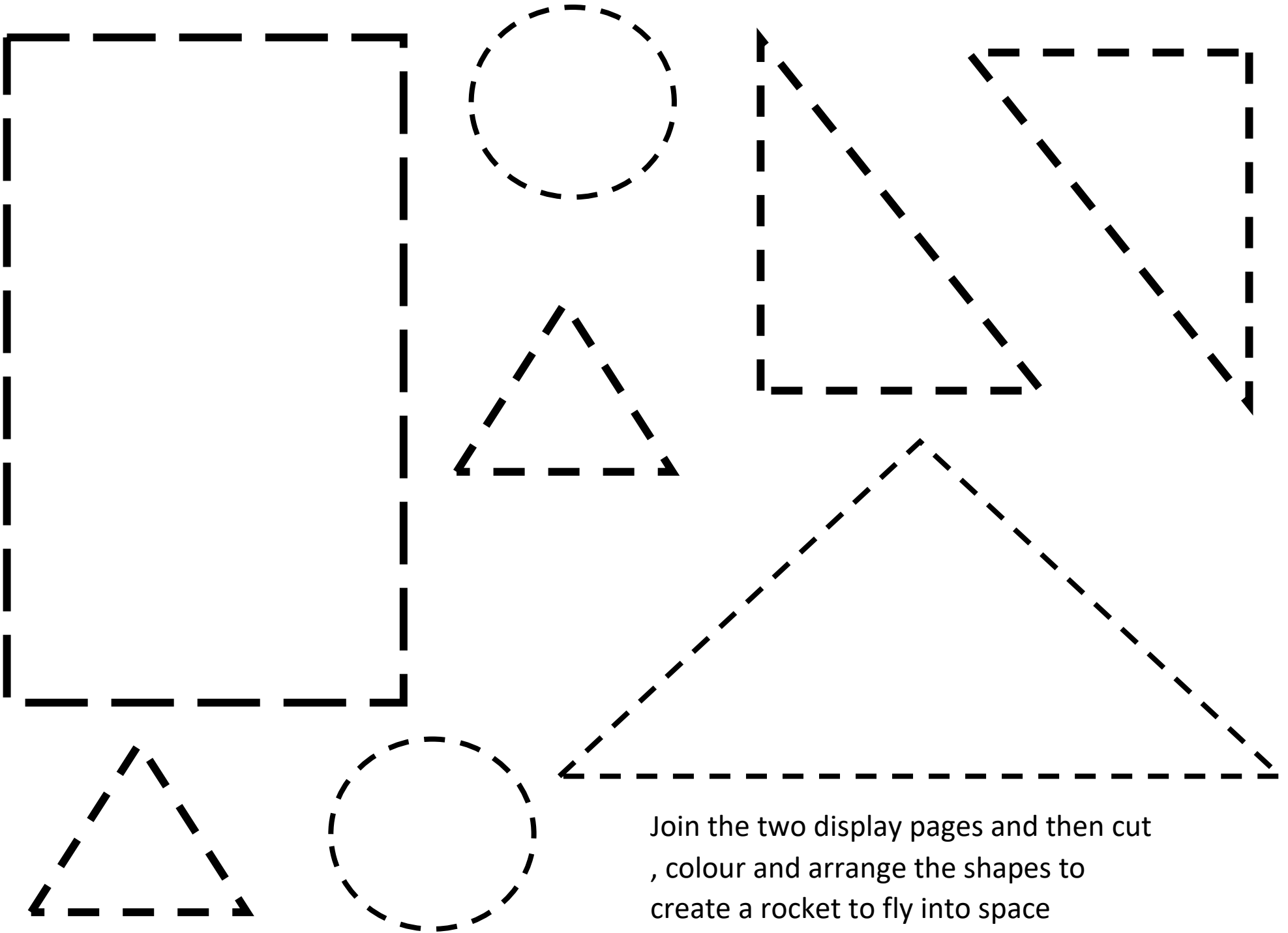

Join the two display pages and then cut  
, colour and arrange the shapes to  
create a rocket to fly into space

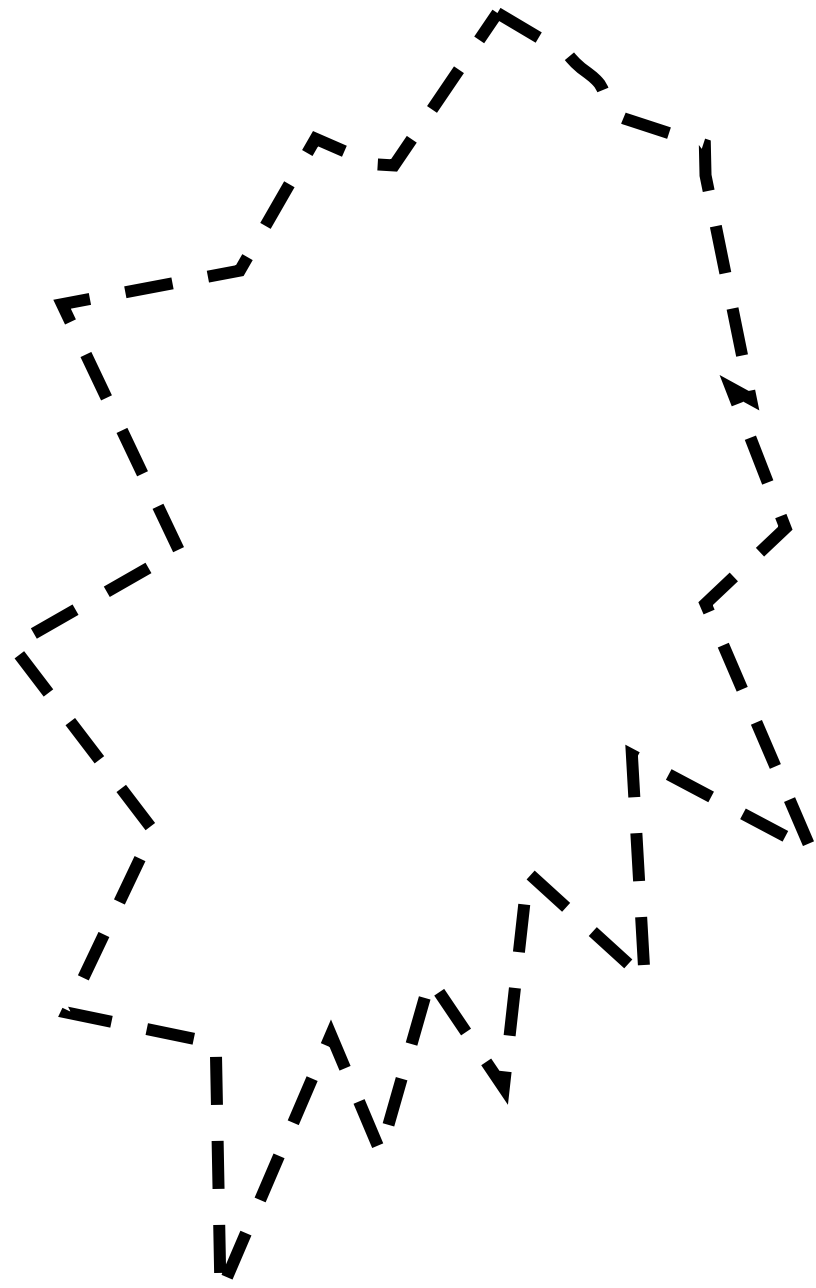
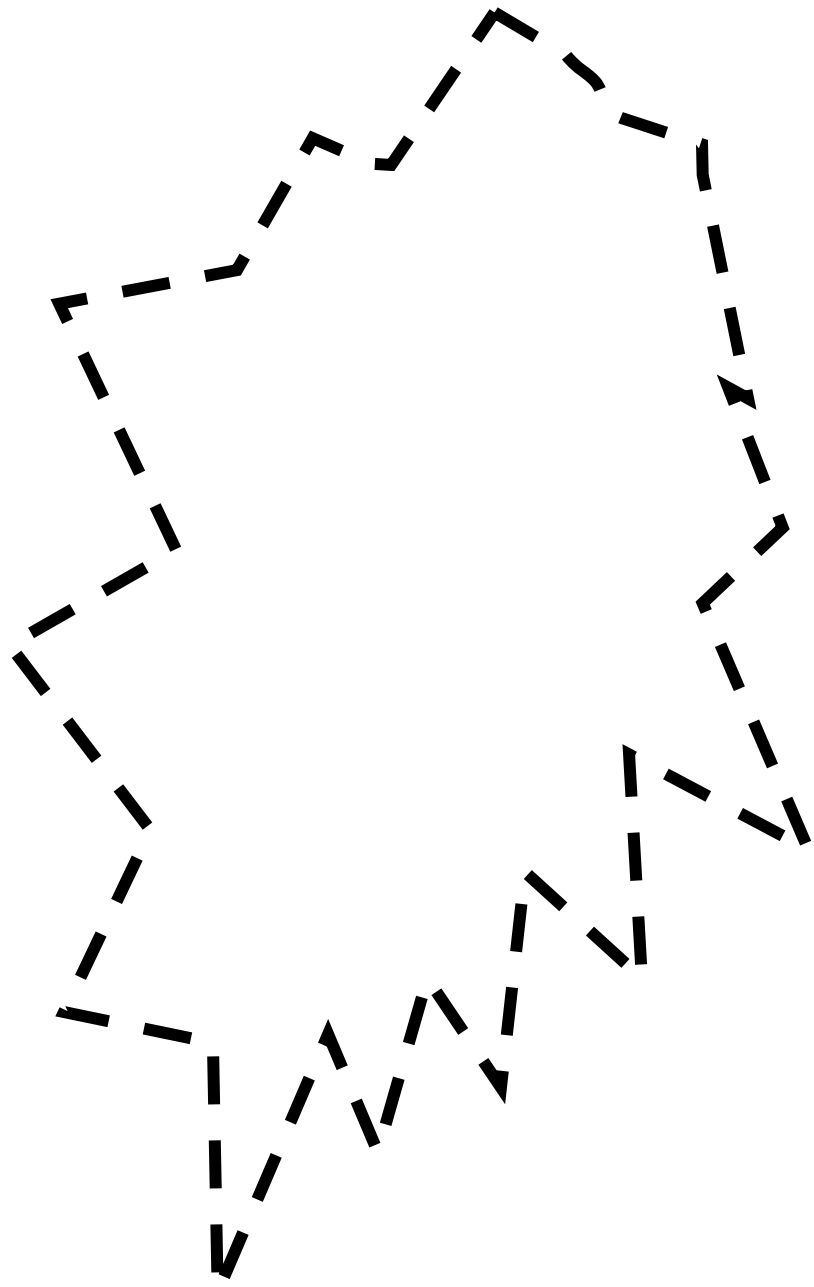

# Five Little Men in a Flying Saucer

5

Five little men in a flying saucer,  
Flew round the Earth one day,  
They looked left and right but they didn't like the sight,  
So one man flew away.

4

Four little men in a flying saucer,  
Flew round the Earth one day,  
They looked left and right but they didn't like the sight,  
So one man flew away.

3

Three little men in a flying saucer,  
Flew round the Earth one day,  
They looked left and right but they didn't like the sight,  
So one man flew away.

2

Two little men in a flying saucer,  
Flew round the Earth one day,  
They looked left and right but they didn't like the sight,  
So one man flew away.

1

One little man in a flying saucer,  
Flew round the Earth one day,  
He looked left and right but he didn't like the sight,  
So one man flew away.

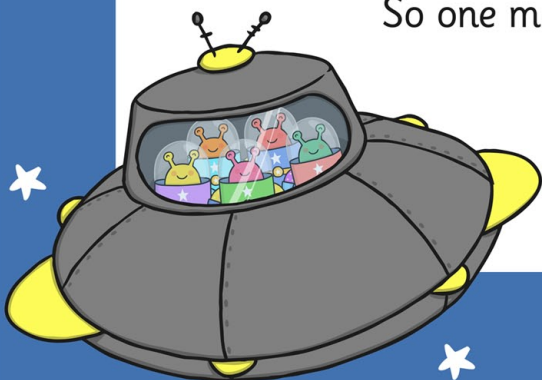

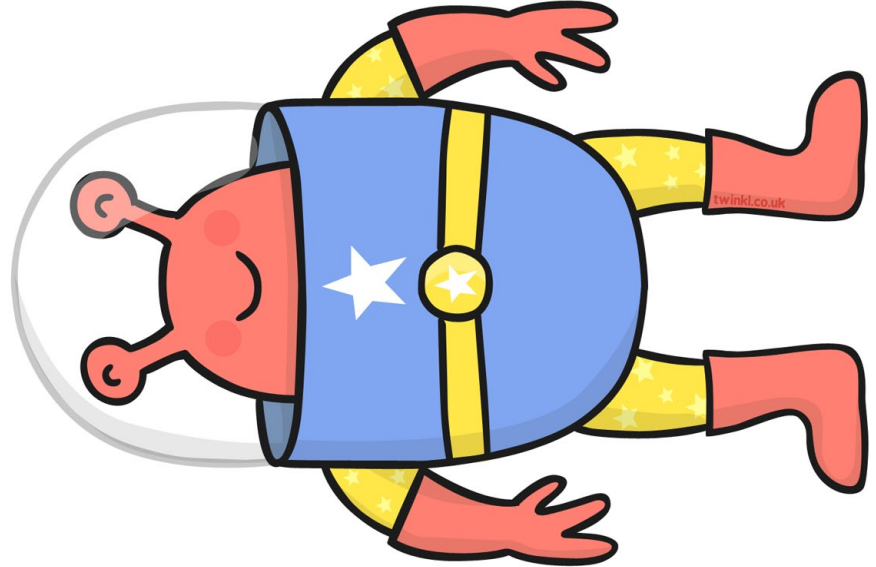
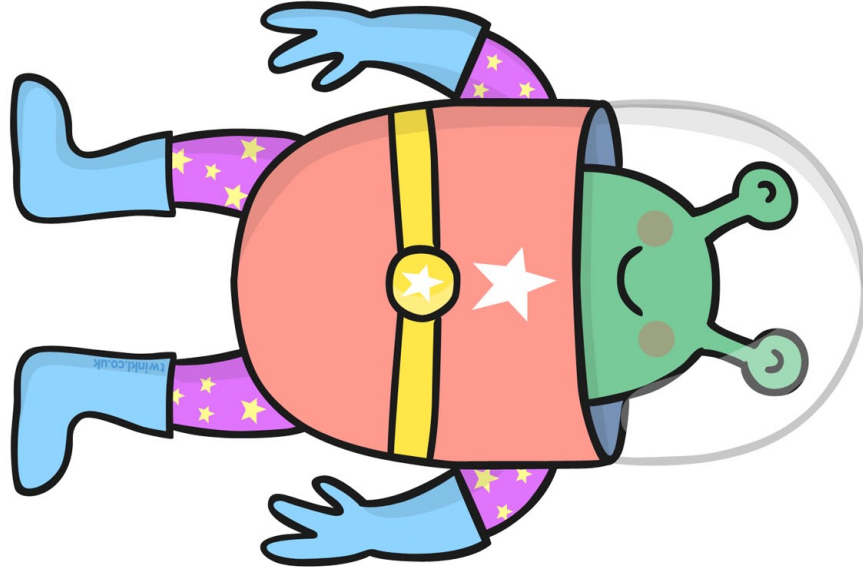
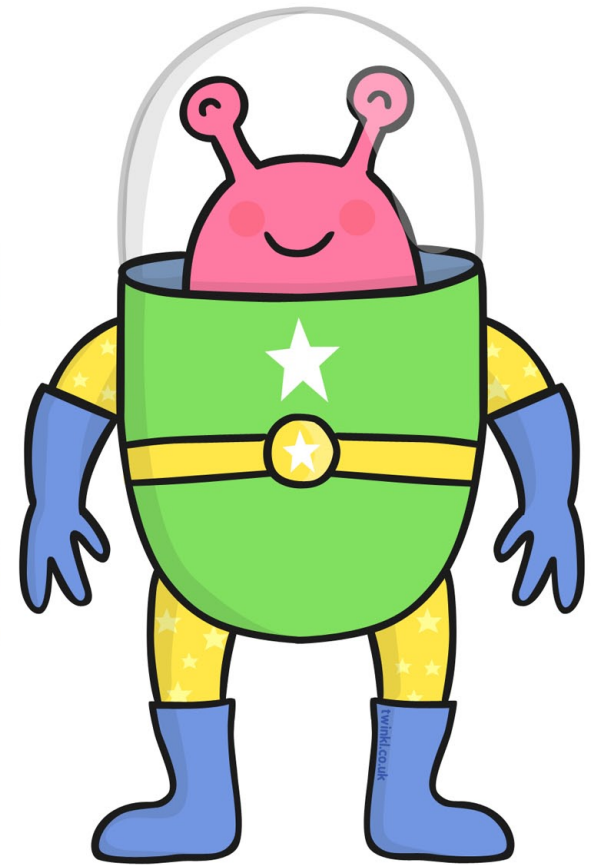
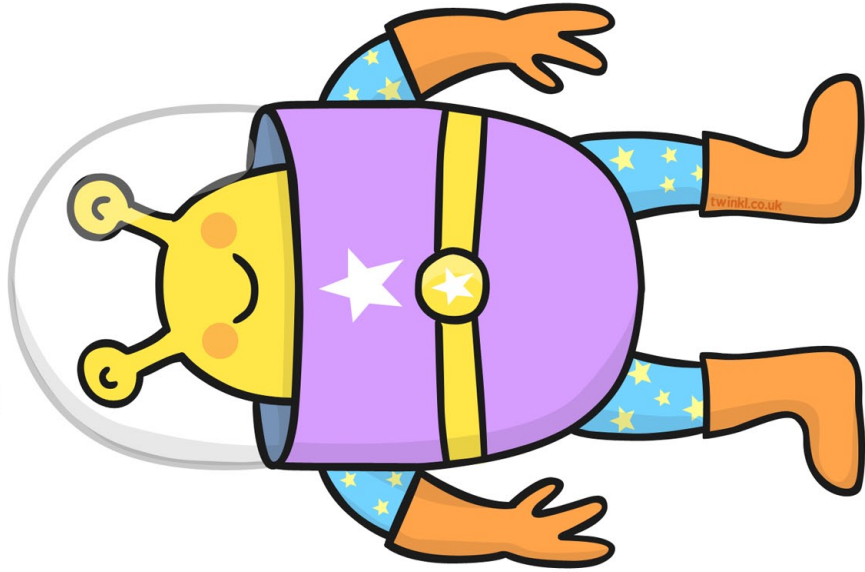
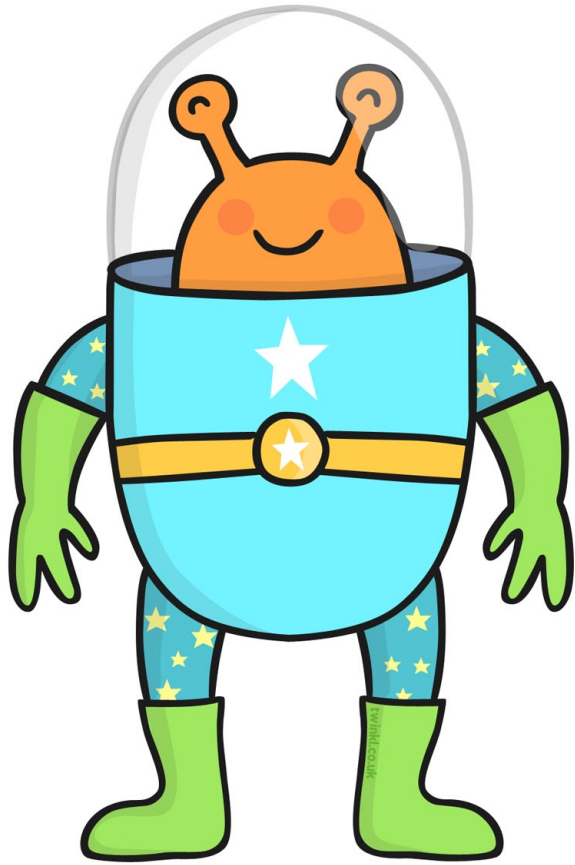



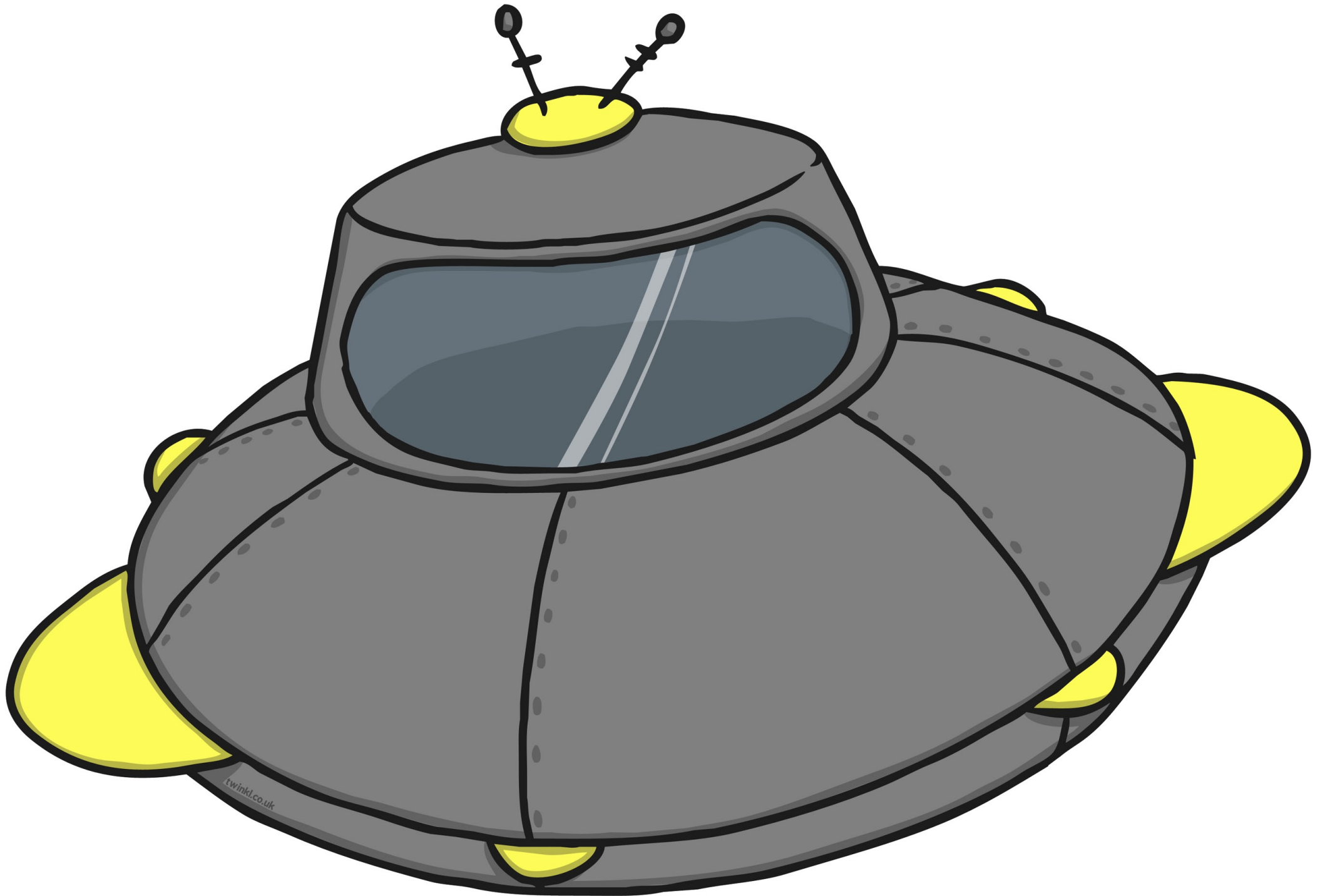

twinkl.co.uk

Create your own solar system Term 3 Week 6 2021 P-Blue

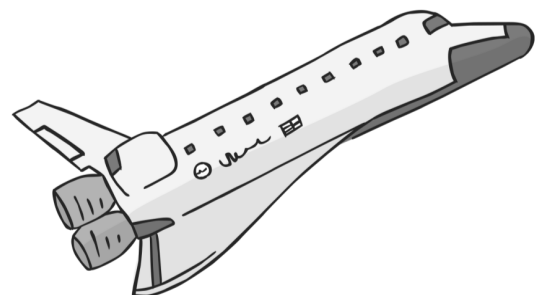
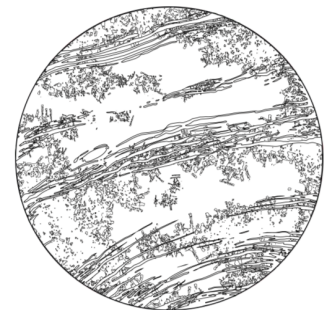
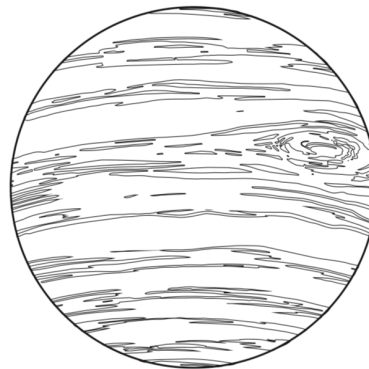
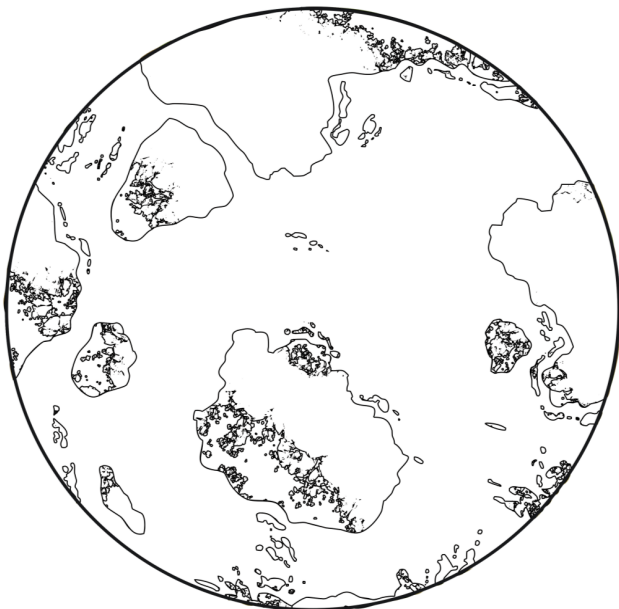
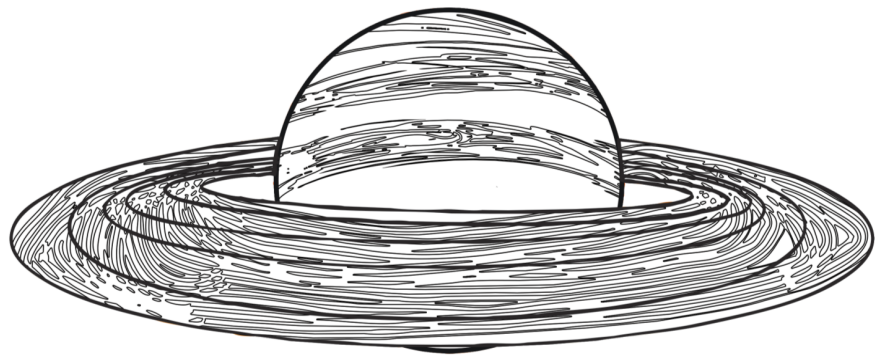
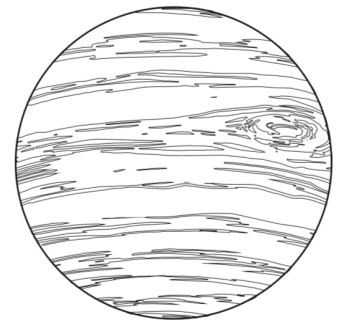
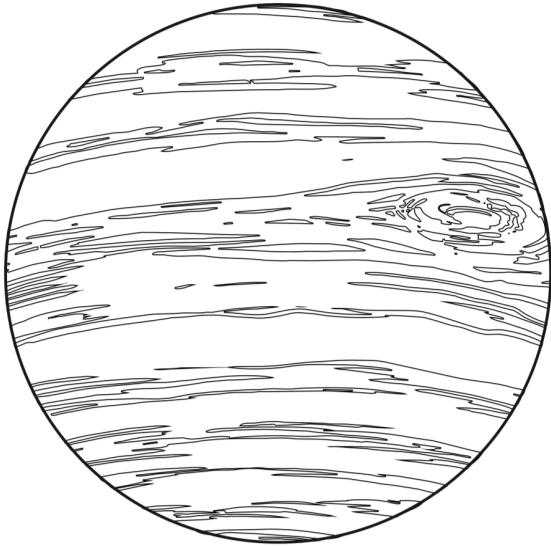
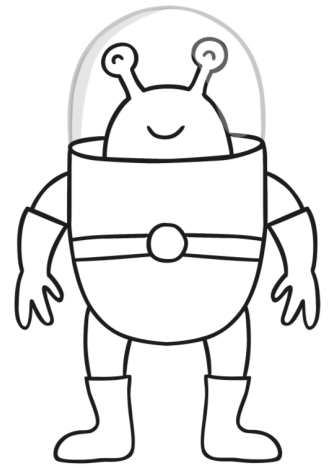
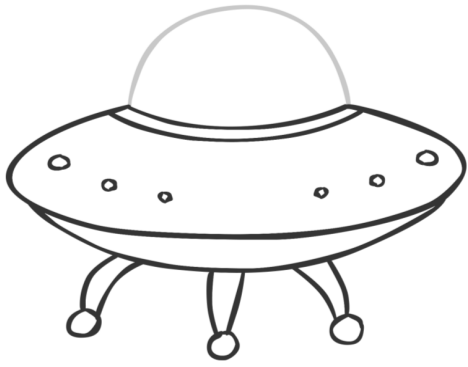

Pencil Control Worksheet- Trace the dotted lines as neatly as you can.

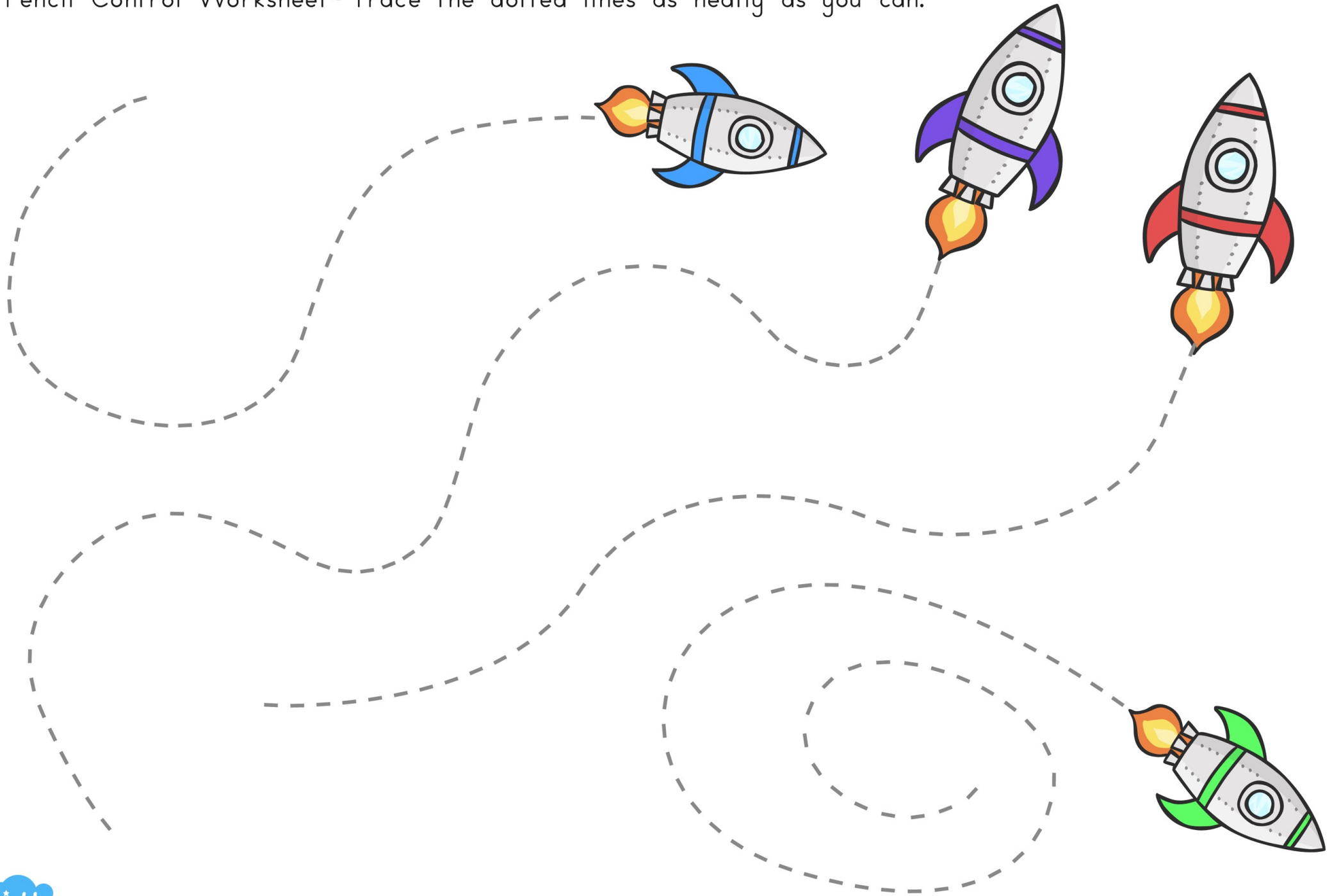

Pencil Control Worksheet- Trace the dotted lines as neatly as you can.

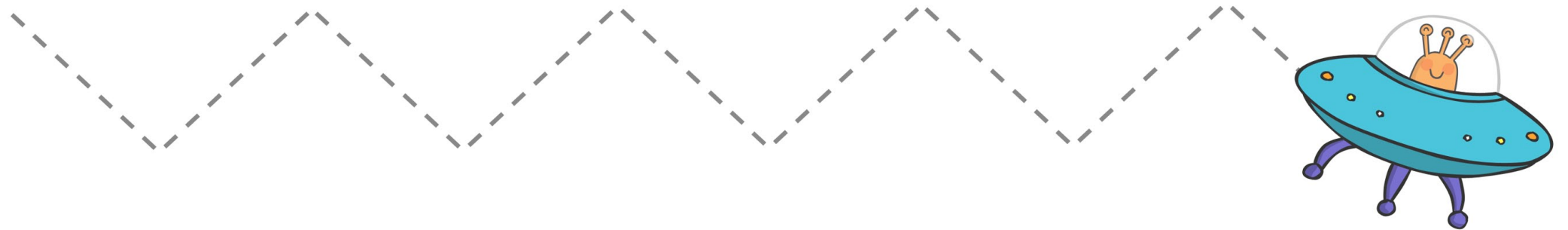
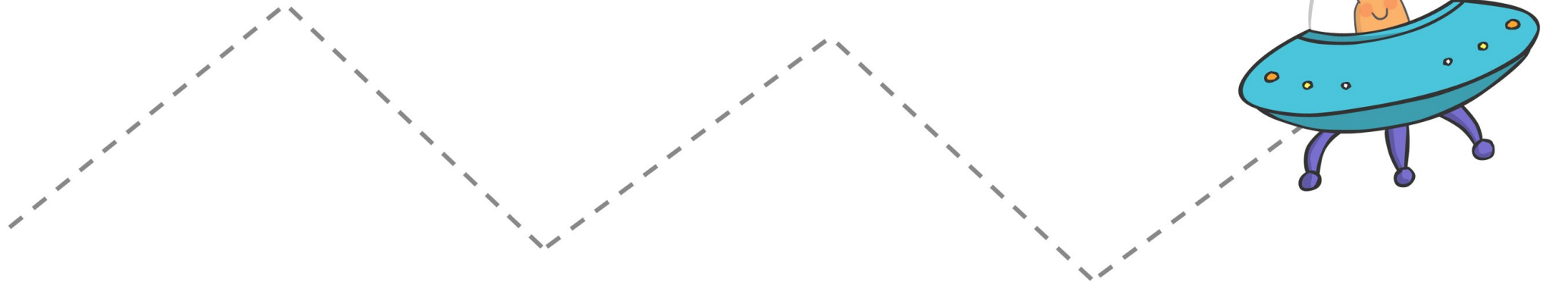

# Side-sliding

Take a  
side step.



Draw a line  
(drag/slide)  
with the  
other foot to  
meet.



Slide  
together,  
slide  
together.



## Old Grey Cat

Ask children to form a circle with two or three children in the middle (they are the 'old grey cats'). Children hold hands and side-slide either clockwise or anti-clockwise together. As they move they sing "I'm a little bird and I live in a tree, you're an old grey cat and you can't catch me". Once the children finish the song they have to run away from the cats. The 'old grey cats' have to try and catch them. Then choose other children to be the 'old grey cats'.

## Snail Relay

Separate children into teams. Mark out a relay track. Children will be running a relay but instead of running they will be sliding like snails. The first child side-slides up and back and has to high five the next child in line. They then do the same until the whole team has finished.

## Shape Game

Cut out coloured shapes from laminated paper. Have a variety of different colours for each shape. Place them around a designated area on the ground. When the music starts, ask children to side-slide around the shapes. When the music stops they have to stand on one of the shapes. If there are not enough shapes, the children can share by either having a body part touching the shape or touching someone who is touching the shape. You can ask children questions like 'who is standing on a square?' and 'what colour is the square you are on?'. To make it harder, next time specify that children have to find a red shape or everyone has to find a circle. You can change the mode of travel such as running or hopping.

## Line Sliding

Mark out a line with chalk or masking tape and ask the children to side-slide along the line.



# SIDE SLIDING

for pre-schoolers 3-5 years

with Franky the Frog

## DESCRIPTION

Side sliding is a side to side gallop with minimal bounce. The movement should look smooth and children stay low to the ground.

## POINTS TO REMEMBER

- Before starting the games take a few moments to go over the key teaching cues for side sliding
- Start with the 'Who can side slide like Franky the Frog?' activity, most children will find this movement simple so challenge them to go a little faster or to follow a line on the floor
- If a child is having difficulty side sliding, try breaking up the action into simpler parts. Work on single components such as keeping the body side on, making sure feet touch in the middle and turning the head to watch where they are going without moving their shoulders
- In active play gather a small group of children at a time – first demonstrate the skill and then explicitly teach each component of side sliding
- Don't forget to warm up and cool down
- Demonstrate the skill so that everyone can see
- Positive feedback is the key – have fun detecting and correcting!

## TEACHING CUES

- 1 Turn sideways (use a line or mark on the floor to help children align their feet and shoulders)
- 2 Take a big step to the side
- 3 Slide your trailing foot until your feet are back together
- 4 Make sure you keep your body sideways
- 5 Try and do at least 4 steps in a row

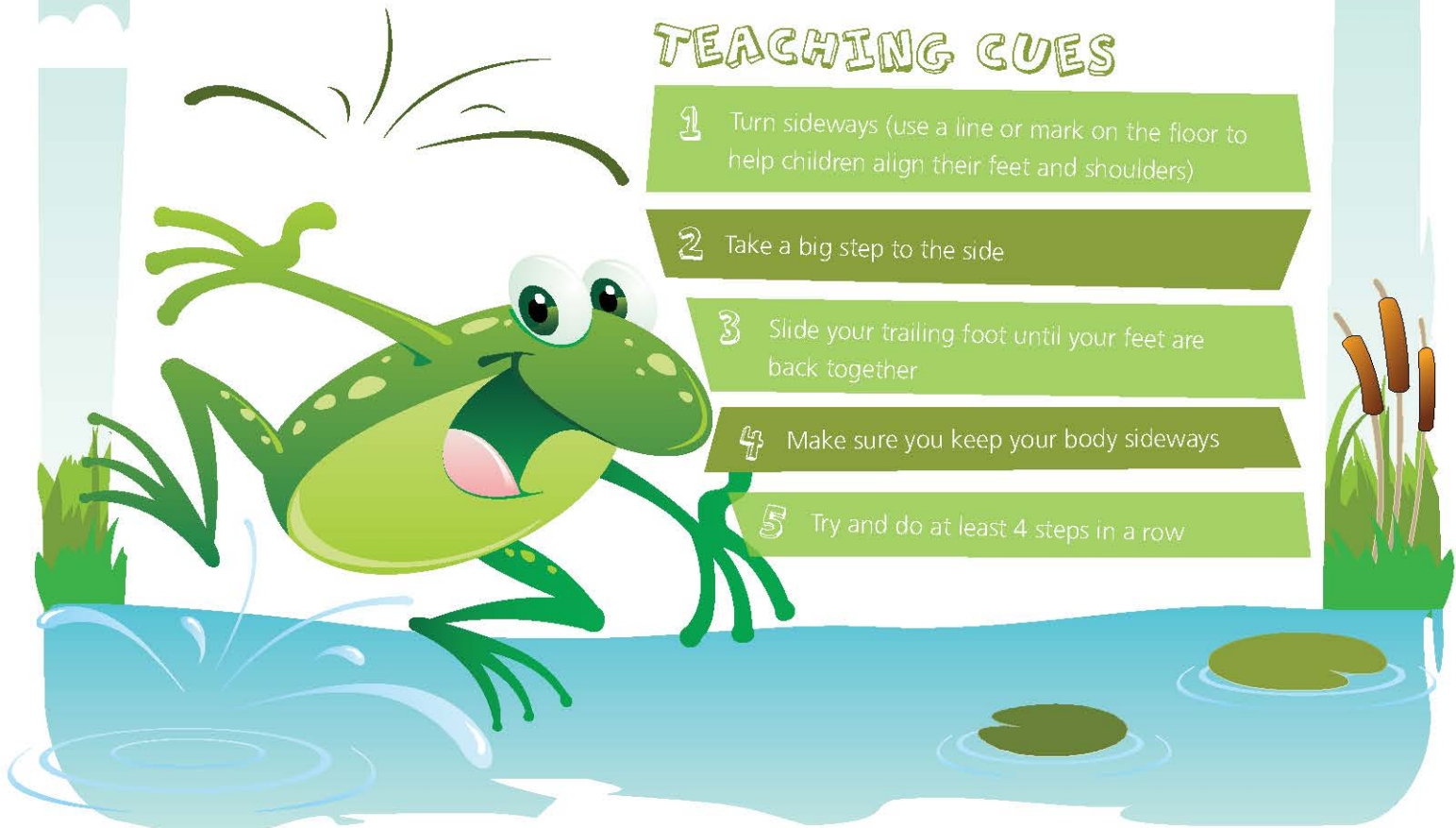



# SIDE SLIDING

for pre-schoolers 3-5 years

with Franky the Frog

## WARM-UP ACTIVITY

A warm-up activity helps children get their muscles and brain ready for moving and sets up good habits for future participation in sport.

Action songs make great warm-up activities, try:

The Ants Go Marching.

## WHO CAN SIDE SLIDE LIKE FRANKY THE FROG?

### Game Set up

Children spread out in a defined area

### Activity

Who can side slide:

- Slow
- Fast
- In a straight line
- Along a balance beam
- On their tip toes
- Sneakily

Franky says "Don't forget to use the FMS lanyard to help you detect and correct!"

## FOLLOW THE FOOTPRINTS

### Equipment

- Footprints (could be laminated paper cut from cardboard, stickers or drawn with chalk)

### Game Set up

- Create a course throughout the yard or inside the room
- Place footprints all around and in different directions

### Activity

- Get children to side slide along the course making sure they slide over every footprint
- This helps children practice bringing their feet together, so they can step their lead foot to the footprint and bring their trailing foot alongside

- Play music to make it fun, try the song 'Sliding' (track 6 of the Munch & Move CD)

Sliding, sliding, sliding, side sliding together

- Encourage older children to slide in both directions

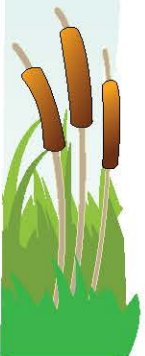

# SIDE SLIDING

for pre-schoolers 3-5 years

with Franky the Frog



## PARACHUTES

### Equipment

A parachute, if you do not have one this activity could also be done using a bed sheet

### Game Set up

- Spread the parachute out in an open space
- Make sure you have adequate staff participating

### Activity

- Children form a circle holding hands and spreading out
- Educators open out the parachute and all children take hold with both hands
- Children and educators side slide around the circle still holding the parachute
- Variations can include:
  - Side sliding with the parachute held up high (above heads)
  - Side sliding with the parachute held down very low
  - Taking 4 steps left and then 4 steps right
  - After a number of side slides an educator calls 'under' and children run underneath the parachute

## SIDE SLIDING SONGS

### Equipment

No equipment is needed, but you may like to use a CD player

### Game Set up

Have children form a circle in an appropriate space

### Activity

Incorporate side sliding into circle songs. Have children hold hands and side slide around the circle singing songs such as:

Here we go round the mulberry bush  
Here we go round the mulberry bush,  
The mulberry bush,  
The mulberry bush.  
Here we go round the mulberry bush  
So early in the morning



# SIDE SLIDING

for pre-schoolers 3-5 years

with Franky the Frog

## SIDE SLIDING SONGS

**Cows in the Meadow**  
(alternate rhyme to Ring around the Rosey)

Fishes in the water,  
Fishes in the sea  
We all jump up  
With a one-two-three!

Cows in the meadow  
Eating all the grass,  
They all fall down  
With a one two three!

**One Grey Elephant...**

One grey elephant balancing,  
step by step on a piece of string,  
thought it was such a wonderful stunt  
so he called for another elephant.

Two grey elephants balancing,  
step by step on a piece of string,  
thought it was such a wonderful stunt  
so he called for another elephant.

Repeat until all children are sliding, then final line:

And what do you think happened??  
THEY ALL FELL OFF!

## COOL DOWN ACTIVITY

A cool down activity helps children relax their muscles and allows some time to settle before they transition to the next part of their day.

**Transition songs or stories make great cool down activities, try: The Belly Button Game.**

Have children imagine their belly button is at the centre of a circle. Ask them to draw big circles as if they have a hula hoop around their waist. Try 3 circles one direction and then 3 the other way, you could also try circles with their eyes closed, up high, down low and end with children seated making tiny circles with their belly buttons.



# Paper Helicopter Instructions

Cut along the solid lines and fold along the dashed lines.

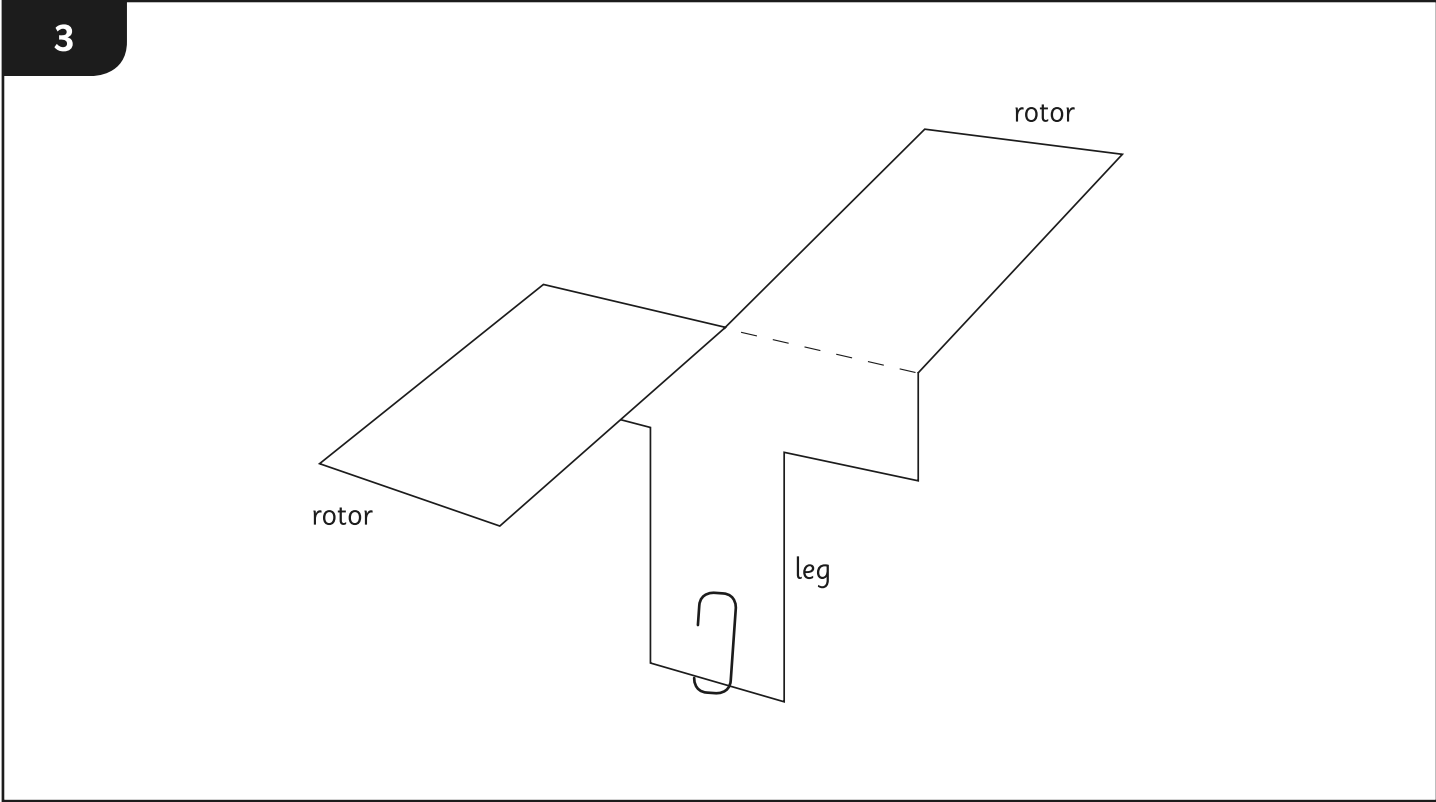
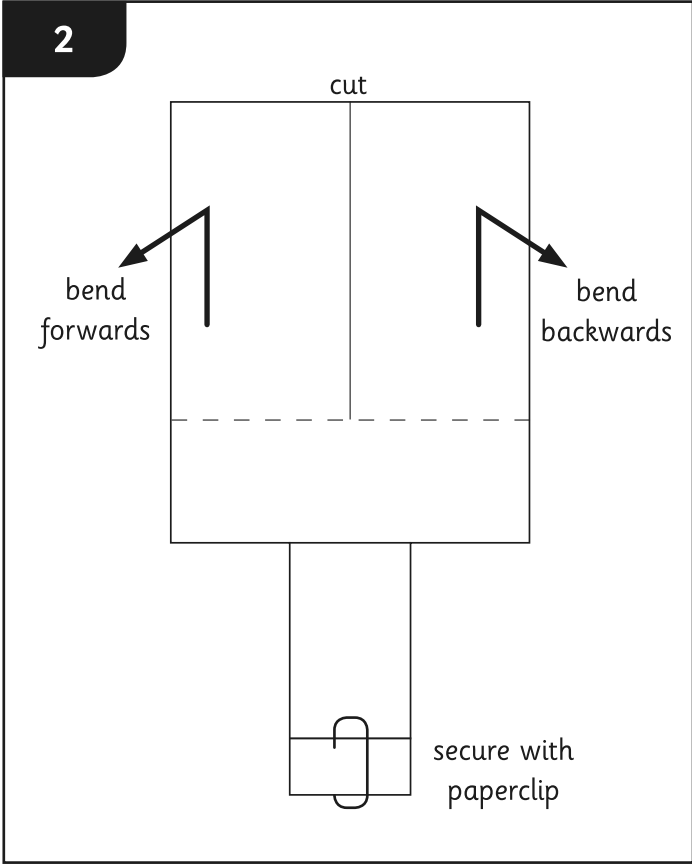
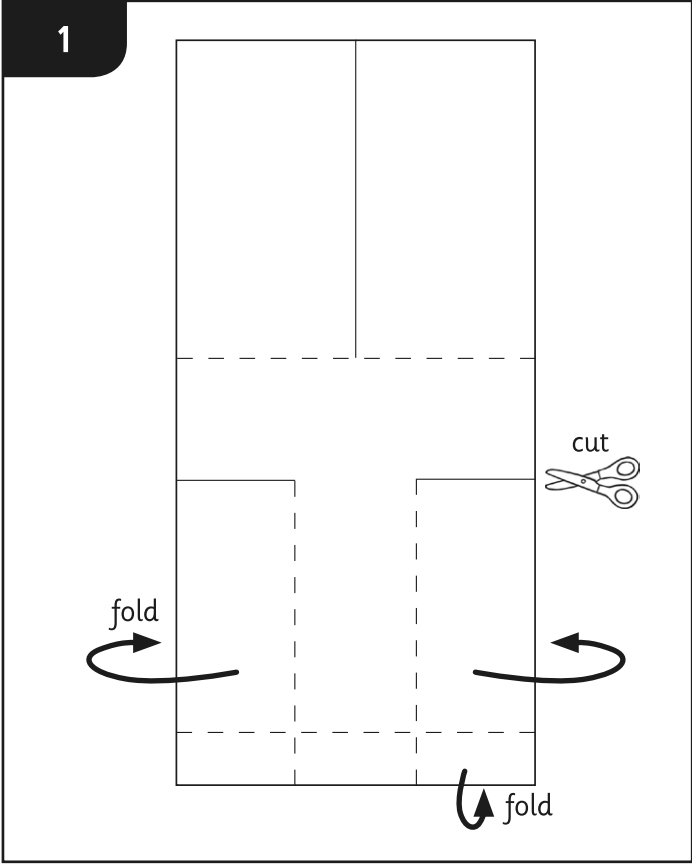

# Paper Helicopter Template

